



## European Technical Assessment

**ETA-20/1169**  
**of 29/01/2022**

### General Part

<b>Technical Assessment Body Issuing the European Technical Assessment:</b>	Element Materials Technology Rotterdam B.V.
<b>Trade Name of the Construction Product:</b>	Posi-Joist™, Posi-Joist™ (Staggered Web), Trim-It™, Posi-Stud™, & X-Rafter™
<b>Product Family to Which the Construction Product Belongs:</b>	EC PAC 13
<b>Manufacturer:</b>	MiTek Industries Limited MiTek House Grazebrook Industrial Estate Peartree Lane Dudley West Midlands DY2 0XW
<b>Manufacturing Plant(s):</b>	Details held on file by Element.
<b>This European Technical Assessment Contains:</b>	40 pages including 6 Annexes which form an integral part of this assessment
<b>This European Technical Assessment is Issued in Accordance with Regulation (EU) No 305/2011, on the Basis of:</b>	EAD 130031-00-0304 – “Metal Web Beams and Columns”
<b>This Version Replaces:</b>	ETA 20/1169, issued on 15/12/2020

Translations of this European Technical Assessment in other languages shall fully correspond to the original issued document and should be identified as such.

Communication of this European Technical Assessment, including transmission by electronic means, shall be in full (excepted the confidential Annex(es) referred to above). However, partial reproduction may be made, with the written consent of the issuing Technical Assessment Body. Any partial reproduction has to be identified as such.

## 1 Technical Description of the Product

Posi-Joists™, Posi-Joists™ (Staggered Web), Posi-Stud™, Trim-It™ and X-Rafter™, hereafter collectively referred to as ‘Posi™ metal web beams and columns’ are shallow parallel-chord trusses in which structural timber flanges are connected to each other by a system of triangulation provided by thin gauge steel webs. The structural timber flanges shall be strength graded in accordance with EN 14081-1 and with or without finger joints. Finger jointed timber shall meet the requirements of EN 15497. A web is a thin gauge steel member that is fixed to the flanges of the beam or column by the pressed insertion of integral nail-plates. The webs are produced in end-joined pairs, called V-webs, but may be inserted individually. A typical joist is shown in elevation in Figure A 1-1 and in cross-section in Figure A 1-2 of Annex 1. The range of products is given in Table 1.

**Posi-Joists™** are metal web beams or columns with the web arrangement on one side mirrored on the other side. The web arrangement is symmetrical relative to a plane aligned with the length and depth of the beam or column so that the webs are always in pairs. This is the most common web arrangement, an example of which is shown in Figure A 1-1.

**Posi-Joists™ (Staggered Web)** are Posi-Joists which at any point in the mid-span zone of the joist have individual webs or V-webs on one side only of the joist with the adjacent webs or V-webs being on the opposite side of the joist, although webs on opposite sides may overlap. Staggered webs are not permitted adjacent to a support.

**Posi-Stud™** joists utilize individual PS8 or PS9 webs with the angles of the webs identical to those of Posi-Joists. The webs in Posi-Studs are crossed and staggered.

**Trim-It™** joists are PS10 Posi-Joists in which the end webs are replaced with an I-joist insert. The I-joist insert has a depth of 159 mm, which is the clear depth between the Posi-Joist flanges, and softwood flanges of the same width as the Posi-Joist flanges. The I-joist insert is both nailed and plated in place to allow easy trimming on site.

**X-Rafter™** joists use half the number of webs compared with Posi-Joists, with the webs arranged in a crossed pattern, providing a half triangulation system. The X-Rafter joists generally have the flanges arranged with the larger cross-sectional dimension in the direction of the load application.

**Table 1: Posi Product Range**

Distance Between Flanges (mm)	Web ID	POSI Joists Full Web & Staggered Web	Trim-It	POSI-Stud	X-Rafter
108	PS8	✓	-	✓	✓
131	PS9	✓	-	✓	-
159	PS10	✓	✓	-	-
159	PS10+	✓	-	-	-
210	PS12	✓	-	-	-
279	PS14	✓	-	-	-
327	PS16	✓	-	-	-

This ETA covers metal web beams where the distance between the flange members ranges between 108 and 327mm, with a minimum width of the flanges of 35mm. The depth of the flanges shall be such that the cross-sectional area of a flange is at least 2000mm<sup>2</sup>.

Where necessary the flanges are end-jointed using punched metal plate fasteners (subsequently referred to as nail-plates) pressed into the top and bottom faces of the flanges, as shown in Figure A 1-5.

This ETA provides the option for the flanges of the metal-web joists to be made of preservative treated timber.

In case of timber being used with preservatives, additional information shall be provided and the timber shall comply with EN 351-1:2007 under the 98/8/EC Directive (as amended).

On elevation pairs of webs are generally V-shaped with integral nail-plates at each end and at the root of the V-web as shown in Figure A 1-3. These integral nail-plates are pressed into the sides of the flanges to form triangulated frameworks of the type shown in Figure A 1-1. For joists or parts of joists under high load, double webs might be used whereby two webs are placed adjacent and parallel to each other on each side of the flanges as shown in Figure A 1-6. It can be seen from Figure A 1-6 that half V-webs are used to make up a double web at the end of a joist, whilst in the middle of joists double webs are generally achieved by inverting alternate V-webs.

The nominal horizontal module of the V-webs ranges from 600mm to 728mm. In order to achieve joists of any length one of the following three strategies is followed:

- A Vierendeel bay is formed in the joist by fixing two short timber verticals between the flanges as shown in Figure A 1-7. The distance between the timber verticals is not permitted to exceed the horizontal module of the steel V-web.
- The metal-web triangulation is discontinued locally such that the final webs on opposite sides of the non-triangulated zone are parallel to each other as shown in Figure A 1-8. The maximum extent of the non-triangulated zone along either flange is half the horizontal module of the steel V-web.
- The metal-web triangulation is discontinued locally with a vertical timber post fixed equidistant from the nearest metal webs as shown in Figure A 1-9. The maximum distance along either flange from the centre of the post to the nearest integral nail plate is half the horizontal module of the steel V-web.

## **2 Specification of the Intended use(s) in Accordance with the Applicable European Assessment Document (hereinafter EAD)**

Posi metal web beams and columns are intended for use in buildings as load bearing components in elements such as walls, roofs and floors. They are for use in Service Classes 1 and 2 as defined in EN 1995-1-1 and in Use Classes 1 and 2 as defined in EN 335 Parts 1 and 2.

Posi-Joists are not considered suitable for Service Class 3 conditions.

Metal-web beams and columns are intended for use in building constructions with an assumed intended working life of 60 years. This gives an indication as to the working life in normal use conditions; however it cannot be interpreted as a guarantee.

National specifications exist to allocate timber to a desired service life by use class or for specific end uses. These allocations are dependent on the natural durability of the timber or the level of preservative treatment. There are no equivalent product classifications within EN standards.

## 3

**Performance of the Product and References to the Methods used for its Assessment****Table 2: Essential Characteristics and Performance of the Product**

No.	EAD Clause	Essential Characteristic	Product Performance
Basic Works Requirement 1: Mechanical Resistance and Stability			
Strengths of Webs			
1	2.2.1.2	Single web characteristic anchorage strength in tension at end support	Table A 2-3 and Table A 2-5
2	2.2.1.3	Single web characteristic anchorage strength in tension at internal node	Table A 2-3 and Table A 2-5
3	2.2.1.4	Single web characteristic anchorage strength in compression	Table A 2-3 and Table A 2-5
4	2.2.1.5	Double web characteristic anchorage strength in tension	Table A 2-3 and Table A 2-5
5	2.2.1.6	Double web characteristic anchorage strength in compression	Table A 2-3 and Table A 2-5
6	2.2.1.7	Single web characteristic compression buckling strength	Table A 2-4 and Table A 2-6
7	2.2.1.8	Double web characteristic compression buckling strength	Table A 2-4 and Table A 2-6
Strength of flanges			
8	2.2.1.9	Flanges – bending strength	Table A 2-1
9	2.2.1.10	Flanges – tension strength parallel to grain	Table A 2-1
10	2.2.1.11	Flanges – compression strength parallel to grain	Table A 2-1
11	2.2.1.12	Flanges – compression strength perpendicular to grain	Table A 2-1
12	2.2.1.13	Flanges – shear strength parallel to grain	Table A 2-1
13	2.2.1.14	Flanges – characteristic density	Table A 2-1
14	2.2.1.15	Flanges – mean density	Table A 2-1

No.	EAD Clause	Essential Characteristic	Product Performance
Member stiffnesses			
15	2.2.1.16	Flange - modulus of elasticity in bending	Table A 2-1
Joint stiffnesses			
16	2.2.1.18	Web-flange joint slip modulus: single web	Table A 2-8 and Table A 2-9
17	2.2.1.19	Web-flange joint slip modulus: double web	Table A 2-8 and Table A 2-9
Other			
18	2.2.1.20.1	Creep	Table A 2-7
19	2.2.1.20.2	Duration of Load	Table A 2-2
20	2.2.1.21	Dimensional Stability	Annex 4
Basic Works Requirement 2: Safety in Case of Fire			
21	2.2.2.1	Reaction to Fire	Section 3.2.1
22	2.2.2.2	Resistance to Fire	Section 3.2.2
Basic Works Requirement 6: Energy Economy and Heat Retention			
23	2.2.3.1	Thermal Resistance	Section 3.6.1
24	2.2.3.2	Thermal Bridging	Section 3.6.2
Basic Works Requirement 7: Sustainable use of Natural Resources			
25	2.2.4.1	Durability of timber components	Section 3.7.1
26	2.2.4.2	Durability of metal components	Section 3.7.1

### 3.1 Mechanical Resistance and Stability

The following aspects of performance are relevant to this essential requirement for the Posi metal web beams and columns.

#### 3.1.1 Mechanical Resistance and Stiffness

Mechanical properties for Posi metal web beams and columns are given in Annex 2.

#### 3.1.2 Creep and Duration of Load

Creep and Duration of load factors for Posi metal web beams and columns are given in Annex 2.

### **3.1.3 Dimensional Stability**

Factors affecting stability and component tolerances are given in Annex 4.

### **3.1.4 Seismic Evaluations**

No performance determined.

## **3.2 Safety in case of Fire**

The following aspects of performance are relevant to this essential requirement for the Posi metal web beams and columns.

### **3.2.1 Reaction to Fire**

The metal webs are classified non-combustible in accordance with EC Decision 96/603/EC and fulfil the requirements of class A1 according to EN 13501-1: 2007.

The timber flanges are classified as D-s2, d0.

### **3.2.2 Resistance to Fire**

No performance determined. Performance in relation to resistance to fire would be determined for the complete structural element including any associated finishes.

## **3.3 Hygiene, Health and the Environment**

### **3.3.1 Content and/or Release of Dangerous Substances**

Based on the declaration by the Manufacturer, the product does not contain harmful or dangerous substances as defined in the EU database.

Note:

In addition to the specific clauses relating to dangerous substances contained in this European Technical Assessment, there may be other requirements applicable to the products falling within its scope (e.g. transposed European legislation and national laws, regulations and administrative provisions). In order to meet the provisions of the Construction Products Regulation, these requirements need also to be complied with, when and where they apply.

### **3.3.2 Wood Preservatives**

Wood preservatives applied to the timber components shall meet the requirements of Directive 98/8/EC (as amended) – Biocide Products Directive and shall be specified according to EN 599-1:2009+A1: 2013.

If a treatment is required this should be carried out by companies with capacity and skill in accordance with the regulations valid in the place of use. In this case the treated timber component shall meet the requirements of EN 351-1:2007.

In Service Classes 1 and 2, where the moisture content of timbers will rarely exceed 20%, the risks of fungal decay are low and preservative treatment of timbers is not normally required.

If preservative treatment is used:

- (a) Both double vacuum treatments with organic solvent-based preservatives and boron diffusion do not have a corrosive effect on metal fastenings in these conditions.

- (b) In the situations where CCA preservatives are permitted, the requirements of Directive 2003/2/EC for the preservative to be adequately fixed before treated timber is marketed (intended to promote the safety of those handling it), will ensure it does not present a risk of corrosion to metal fastenings used with it. Provided the timbers are in the conditions of Service Class 1 or 2, the treatment does not have a corrosive effect on metal fastenings. (Note: CCA treatment is subject to restricted use under the European Biocide Products Directive.)
- (c) In residential and domestic situations where arsenic-free aqueous copper preservatives are used in place of CCA preservatives, provided the treated timbers are given adequate time for the preservative to become fixed (normal good practice and considerations of practicability will achieve this), and provided the timbers are in the conditions of Service Class 1 or 2, the treatment does not have a corrosive effect on metal fastening.
- (d) EN 15228 states that treatments with a penetration class not exceeding NP2 according to EN 351-1:2007 can be assumed not to have an effect on strength and stiffness. According to EN 351-1:2007 (Table 1) preservative treatments of class NP1 and NP2 have a maximum penetration of 3mm, and EN 336:2013 allows for -1mm to +3mm manufacturing tolerance without causing any reduction in the strength class. Therefore, providing preservatives of class NP1 or NP2 are used, they will have no effect on the structural properties of the timber.

### **3.4 Safety and Accessibility in Use**

Not Relevant.

### **3.5 Protection against Noise**

Not Relevant

### **3.6 Energy Economy and Heat Retention**

#### **3.6.1 Thermal Resistance**

Not determined

#### **3.6.2 Thermal Bridging**

Posi metal web beams and columns shall be connected to the outer walls and other structures of a building in such a way that thermal bridges are avoided as far as possible. The effect of any condensation risk shall be considered as part of the appraisal of the overall building construction.

### **3.7 Sustainable Use of Natural Resources**

#### **3.7.1 Durability**

Posi metal web beams and columns can be used in Service Classes 1 and 2 according to Eurocode 5 and in hazard classes 1 and 2 as specified in EN 335:2013.

The Posi metal webs are suitable for use in environments with corrosivity categories C1 and C2 as defined in Table 1 of EN ISO 12944-2

The Posi metal webs are coated with a hot dip zinc coating to Z275 as defined in EN 10346.

The product may be exposed to the weather for a short time during installation.



Unless treated with a suitable timber preservative durability may be reduced by attack from wood boring insects such as long horn beetle, dry wood termites and common furniture beetle, in areas where these are prevalent.

Untreated European redwood and whitewood and most commercial softwoods do not have a corrosive effect on metal fastenings.

Douglas fir is more acidic, but its effect is mitigated by dry service conditions, and precautions against corrosive attack are not normally taken or necessary for Service Classes 1 or 2.

### **3.8 General Aspects Related to the Performance of the Product**

#### **3.8.1 Manufacturing**

Posi metal web beams and columns are manufactured in the factory in accordance with the provisions of this European Technical Assessment as identified during inspection of the plant by the Notified Body.

Changes to the product or production process, which could result in this deposited data/information being incorrect, should be communicated to BM TRADA before the changes are introduced. BM TRADA will decide whether or not such changes affect the ETA and consequently the validity of the CE marking on the basis of the ETA and if so whether further assessment or alterations to the ETA will be necessary.

#### **3.8.2 Installation**

Posi metal web beams and columns shall be installed on the basis of a specific structural design for each installation, using the load bearing capacities given in Annex 2.

The product shall be installed by appropriately competent personnel, following an installation plan and relevant construction details worked out for each construction project. The installation plan shall be based on the manufacturer's technical guidance documents.

##### **3.8.2.1 Installation Instructions**

It is the manufacturer's responsibility to ensure that the specific instructions for installation are provided to the purchaser. This information may be made by reproduction of the respective parts of the European Technical Assessment. In addition all installation data shall be shown clearly on the package and/or on an enclosed instruction sheet, preferably using illustration(s).

#### **3.8.3 Packaging, Transport & Storage**

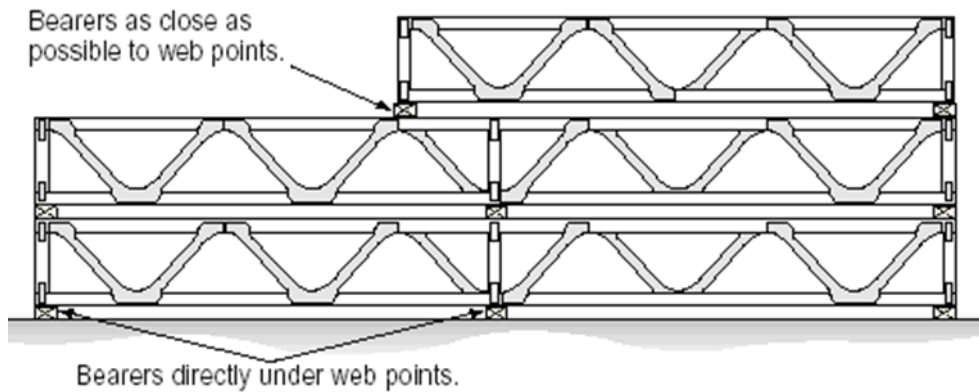
Posi metal web beams and columns shall be protected against harmful wetting during transport and storage.

The product must not be lifted or stored in such a way that bending around the weak axis might cause damage to the joists.

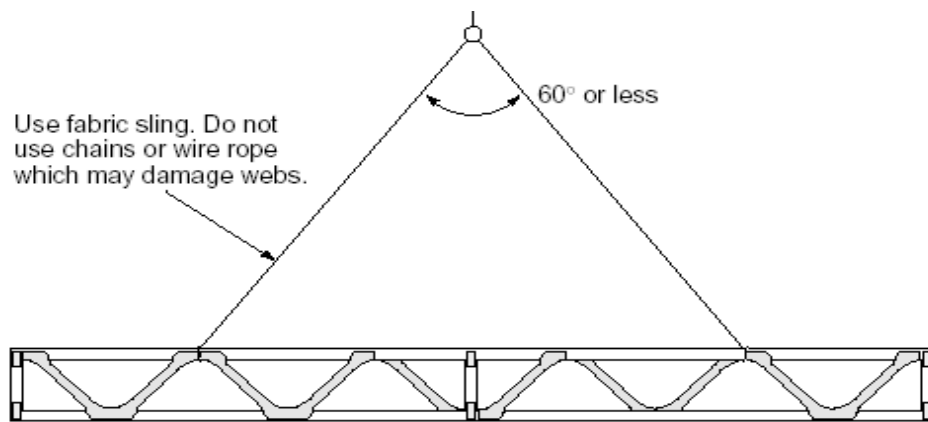
Beams should be stored either vertically (as they would be installed), or flat. Where stacked vertically bearers should be placed at node points and not within the bay of a beam (Figure 3-1)

When loading or offloading with a crane, slings should always be attached to the timber flanges and not to the metal webs, to avoid buckling. Slings should be attached at panel points closest to the quarter points of the beams as shown below (Figure 3-2).

**Figure 3-1: Storage of Posi Products**



**Figure 3-2: Lifting of Posi Products**



The manufacturer must ensure that the information in these provisions is given to those concerned.

#### **4 Assessment and Verification of Constancy of Performance (hereinafter AVCP) System Applied, with reference to its Legal Base**

##### **4.1 System of Assessment and Verification of Constancy of Performance**

According to Commission Decision 1999/92/EC the system of assessment and verification of constancy of performance to be applied to metal web beams and columns is System 1. System 1 is detailed in Commission Delegated Regulation (EU) № 568/2014 of 18 February 2014 Annex 1.2 and provides for the following items.

- (a) The manufacturer shall carry out:
  - (i) factory production control;
  - (ii) further testing of samples taken at the manufacturing plant by the manufacturer in accordance with the prescribed test plan<sup>1</sup>.

---

<sup>1</sup> The prescribed test plan has been deposited with Element Materials Technology Rotterdam B.V. and is handed over only to the notified factory production control certification body involved in the procedure for the assessment and verification of constancy of performance. The prescribed test plan is also referred to as the control plan.

- (b) The notified product certification body shall decide on the issuing, restriction, suspension or withdrawal of the certificate of constancy of performance of the construction product on the basis of the outcome of the following assessments and verifications carried out by that body:
  - (i) an assessment of the performance of the construction product carried out on the basis of testing (including sampling), calculation, tabulated values or descriptive documentation of the product;
  - (ii) initial inspection of the manufacturing plant and of factory production control;
  - (iii) continuing surveillance, assessment and evaluation of factory production control.

In addition, the manufacturer of the metal web beam or column shall draw up a Declaration of Performance (DoP) of the product.

#### **4.2 AVCP for Construction Products for which a European Technical Assessment has been Issued**

Notified bodies undertaking tasks under Systems 1 shall consider the European Technical Assessment issued for the construction product in question as the assessment of the performance of that product. Notified bodies shall therefore not undertake the tasks referred to in points 4.1(b)(i) above.

### **5 Technical Details necessary for the Implementation of the AVCP system, as provided for in the applicable EAD**

#### **5.1 Tasks for the Manufacturer**

##### **5.1.1 Factory Production Control (FPC)**

The manufacturer of the Joist shall exercise permanent internal control of production. All the elements, requirements and provisions adopted by the manufacturer shall be documented in a systematic manner in the form of written policies and procedures. This production control system shall ensure that the product is in conformity with this European Technical Assessment.

The manufacturer shall only use raw materials supplied with the relevant inspection documents. The incoming raw materials shall be subject to controls and tests by the manufacturer before acceptance.

## 5.1.2 Control Plan

No.	Subject/Type of Control (product, raw/constituent material, component - indicating characteristic concerned)	Test or Control Method	Criteria, if any	Minimum Number of Samples	Minimum Frequency of Control
<b>Factory Production Control (FPC)</b> [including testing of samples taken at the factory in accordance with a prescribed test plan]*					
1	Flange material - strength	Check supplier documentation and marking	Graded for structural use to EN 14081-1	NA	Each delivery
2	Moisture content of flange material at fabrication	Check with moisture meter	EN 14250 requirement, max 22%	5	Each shift
3	Flange material	Check geometry	Match specification	1	Each batch and each shift
4	Metal webs	Check supplier documentation and marking	Match specification	NA	Each batch
5	Positioning and fixing of metal webs to flanges	Visual check	Installed in accordance with ETA schedule and design	All beams	NA
6	Geometry of beam	Dimensional check	Within declared tolerance	5	Each batch
7	Marking	Visual check	Match specification	1	Each batch

## 5.2 Tasks of Notified Body

### 5.2.1 Initial Type Testing

Initial Type Testing (ITT) has been undertaken under the responsibility of Element Materials Technology Rotterdam B.V. to verify that the product is manufactured in accordance with this ETA.

Whenever a change occurs in materials or the production process which would significantly change the product characteristics, the tests or assessments shall be repeated for the appropriate characteristic/s.

### **5.2.2 Initial Inspection of Factory and of Factory Production Control**

The Notified Body shall ascertain that the factory and the factory production control are suitable to ensure continuous and consistent manufacture of the product in accordance with this European Technical Assessment.

### **5.2.3 Continuing Surveillance**

The Notified Body shall visit each Production Unit / Factory twice a year for regular inspection. It shall be verified that the system of factory production control and the specified manufacturing process is maintained in accordance with this European Technical Assessment.

The results of product certification and continuing surveillance shall be made available on demand by the certification or inspection body. In cases where the provisions of this European Technical Assessment and the prescribed test plan are no longer fulfilled, the conformity certificate shall be withdrawn by the Notified Body.

Issued in Amsterdam, Netherlands on 29/01/2022

By

A handwritten signature in black ink, appearing to read 'Niresh Somlie', with a long horizontal flourish extending to the right.

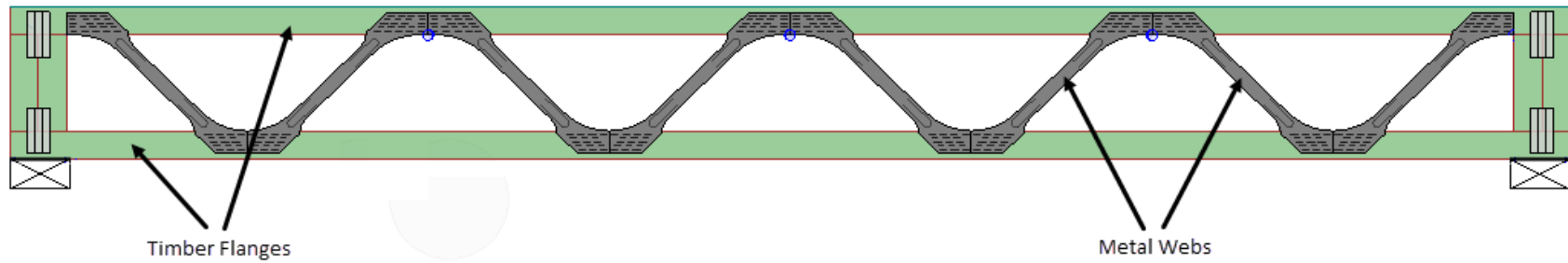
Niresh Somlie

Technical Assessment Body Manager

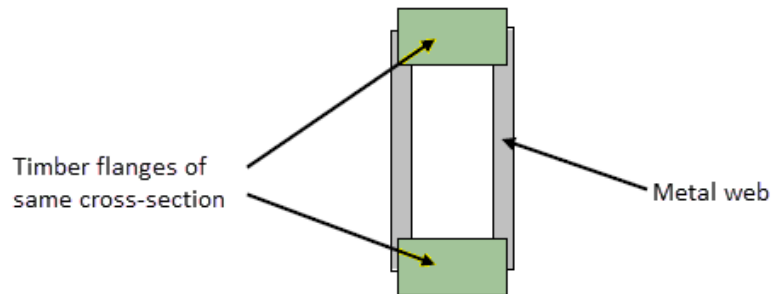
**Annex 1 Description of the Product**

**A1.1 Typical Metal Web Beam and Column Designs**

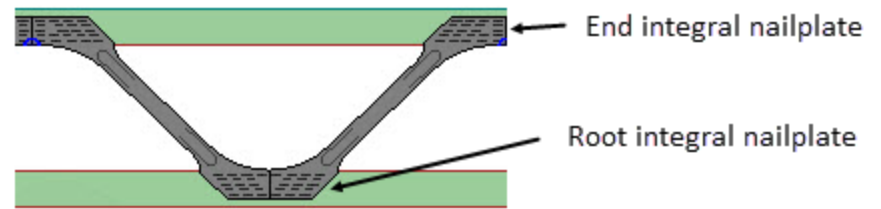
**Figure A 1-1: Elevation on a metal-web joist**



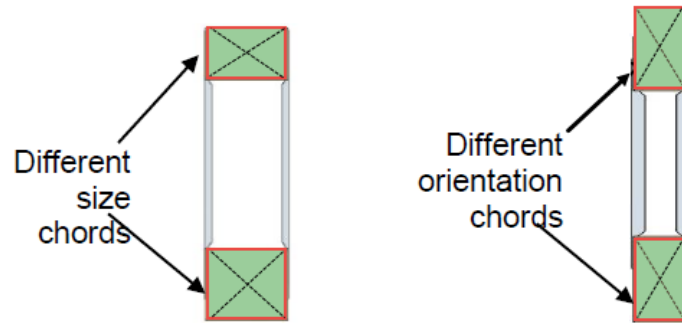
**Figure A 1-2: Cross-section through a metal-web joist**



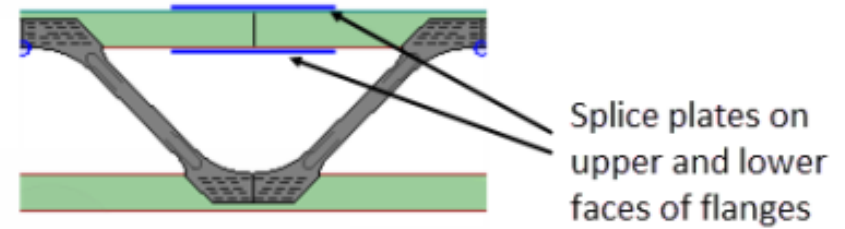
**Figure A 1-3: Elevation on a single metal V-web**



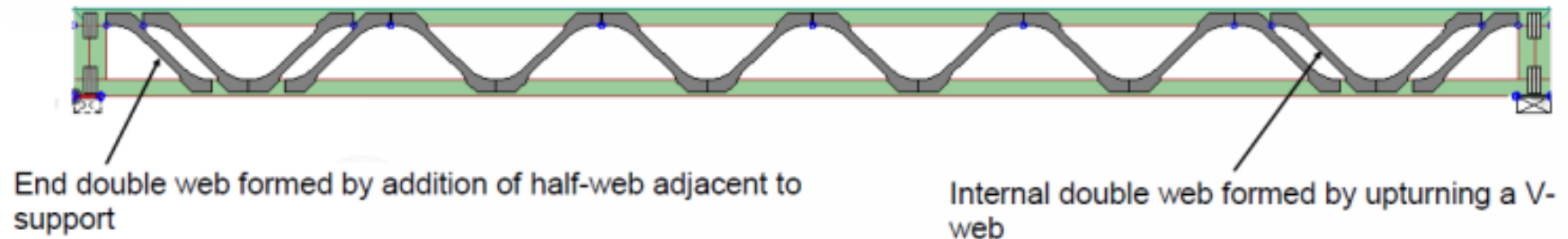
**Figure A 1-4: Cross-sections with different top and bottom flange (or chord) sizes and orientations**



**Figure A 1-5: Location of splice plates on flanges**



**Figure A 1-6: Metal-web joists with double webs**





## A1.2 Example Methods to Achieve any Length of Metal Web Beam or Column

Figure A 1-7: Joist length achieved using a Vierendeel bay

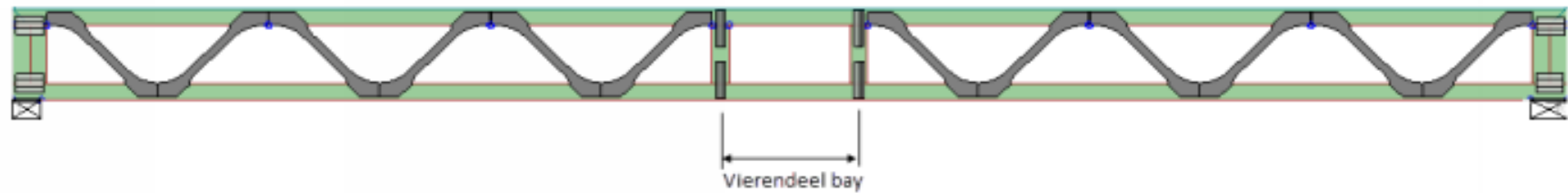
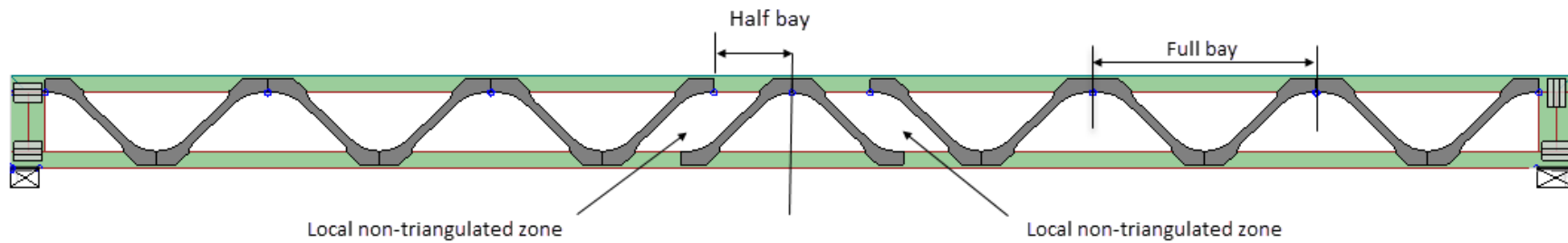
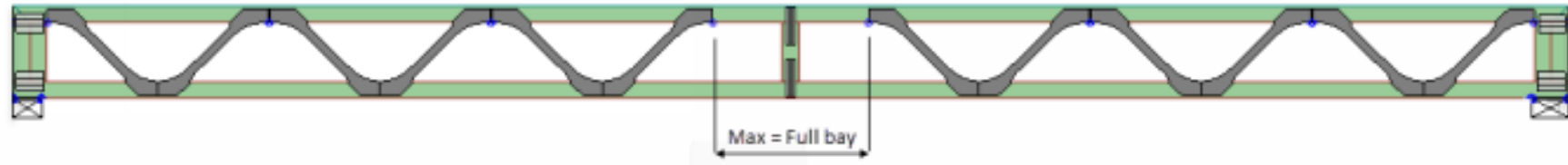


Figure A 1-8: Joist length achieved by locally discontinuing the metal-web triangulation



**Figure A 1-9: Joist length achieved by use of one central column**



## **Annex 2 Mechanical Properties**

### **A2.1 Resistance and stiffness**

#### **A2.1.1 Structural Model**

Posi metal web beams and columns are to be designed using a first order linear elastic plane frame analysis applied to the simplified structural models illustrated in Figure A 2-1, Figure A 2-2, Figure A 2-3 and Figure A 2-4 which are also described below.

##### **A2.1.1.1 Single Webs**

The steel V-webs are assumed to be pinned to the flanges both at their ends and at the root of the V-web. These pinned nodes are located on the flange centrelines and at any junction between webs and a flange, there is a single pinned node located as illustrated in Figure A 2-1 and Figure A 2-3. The system line for any web extends between adjacent top and bottom chord nodes as shown in the Figures. Slip is to be based on a slip modulus,  $k_{ser,SW}$ , which is simulated by a directional spring at the web node.

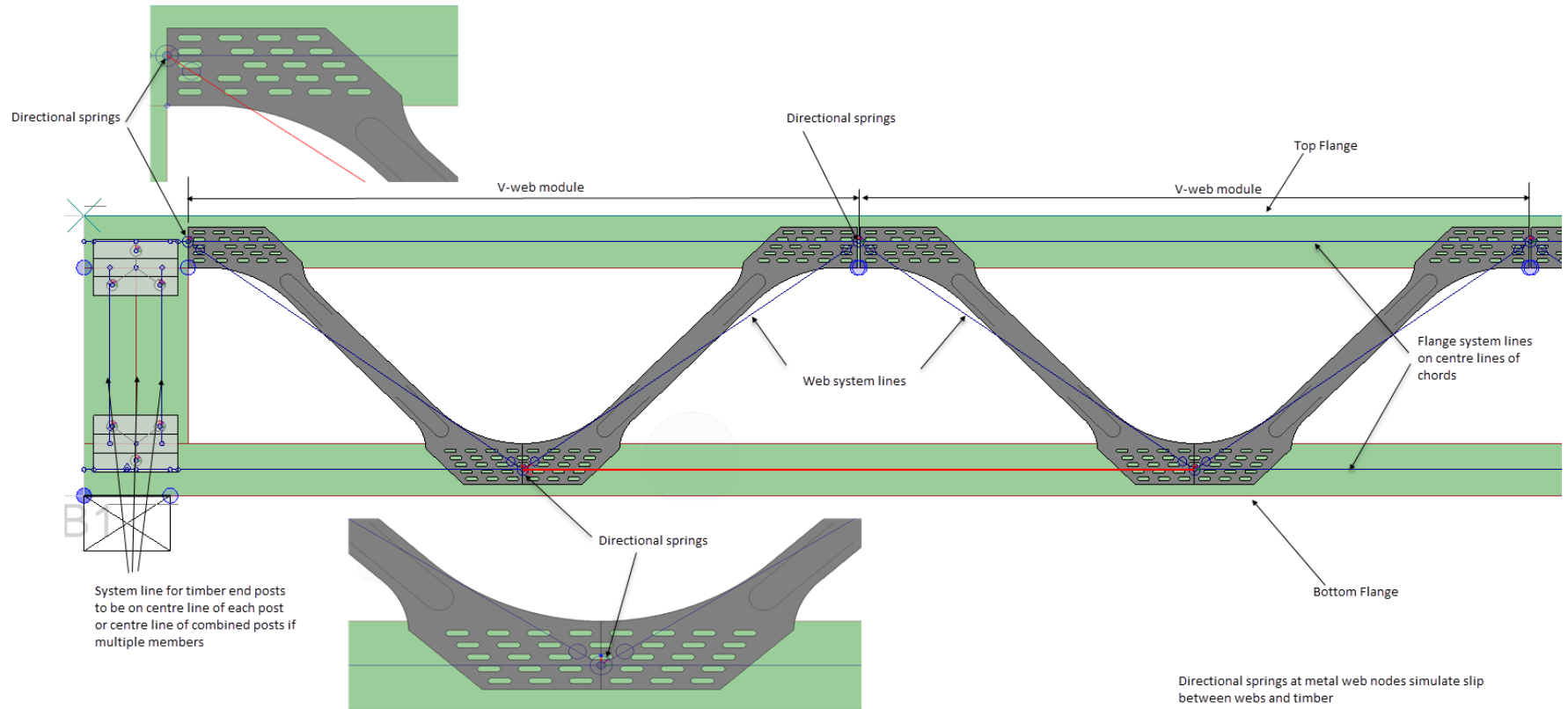
##### **A2.1.1.2 Flanges**

The timber flanges are to be assumed to be continuous past the pinned web nodes, with their system lines being located on the flange centre lines.

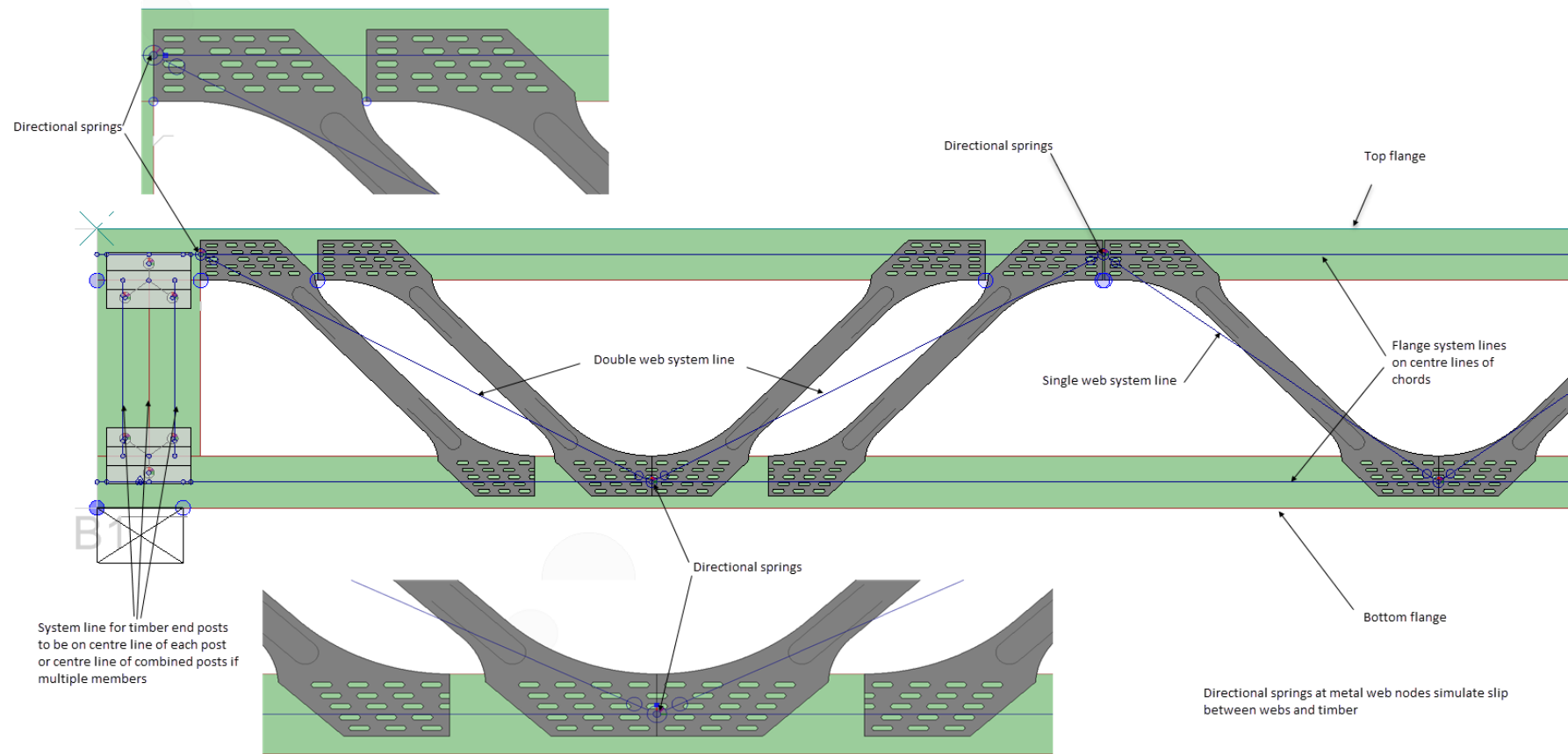
##### **A2.1.1.3 Double Webs**

At all junctions between a double web and a flange, a single pinned node is to be located on the flange centre lines as shown in Figure A 2-2 and Figure A 2-4. The system line for any double web extends between adjacent top and bottom chord nodes as shown in the Figures. Slip is to be based on a slip modulus,  $k_{ser,DW}$ , which is simulated by a directional spring at the web node.

**Figure A 2-1: Structural Model for Metal Web joists with Single Webs - (Not to Scale)**

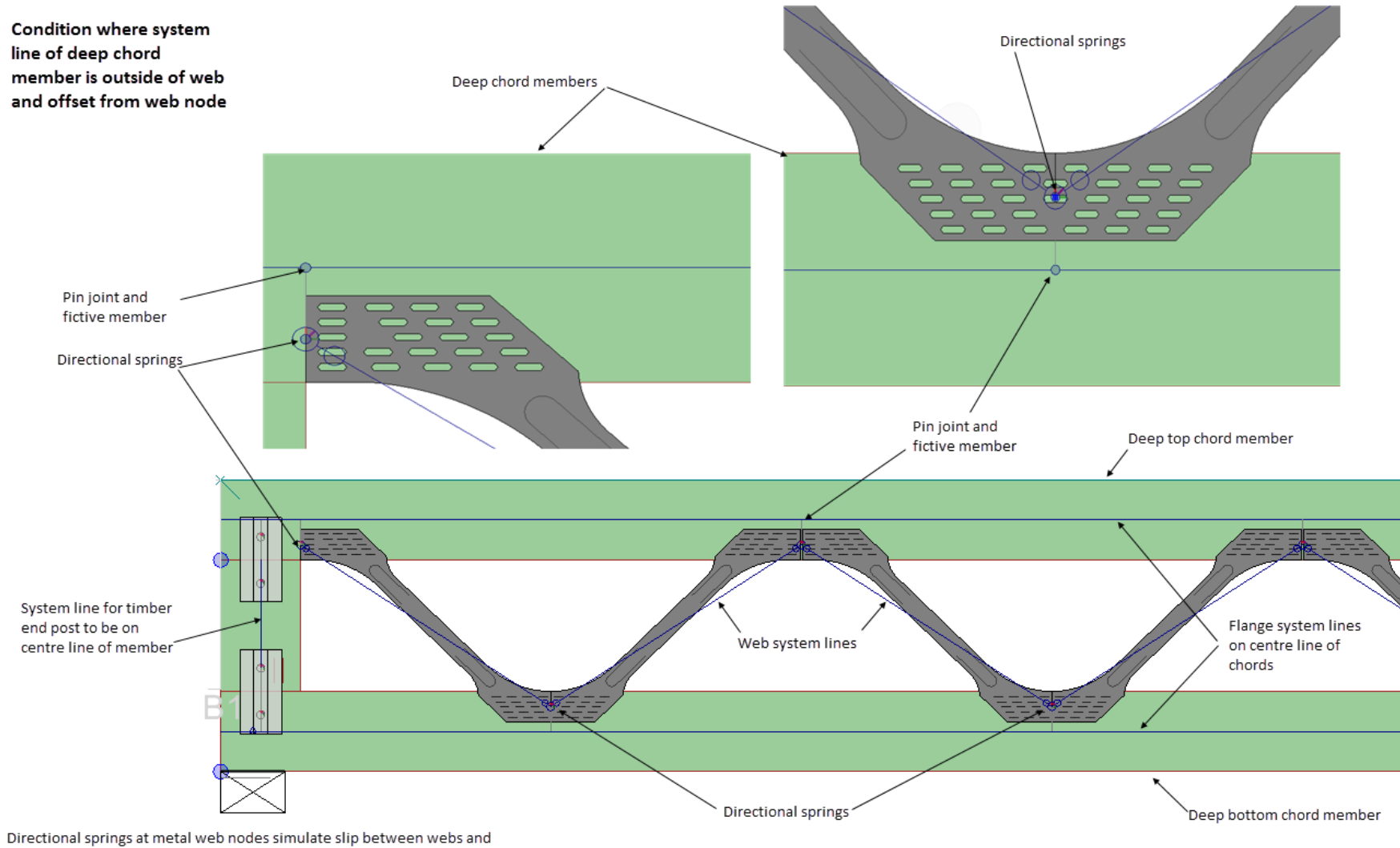


**Figure A 2-2: Structural Model for Metal Web Joists with Double Webs (Not to Scale)**

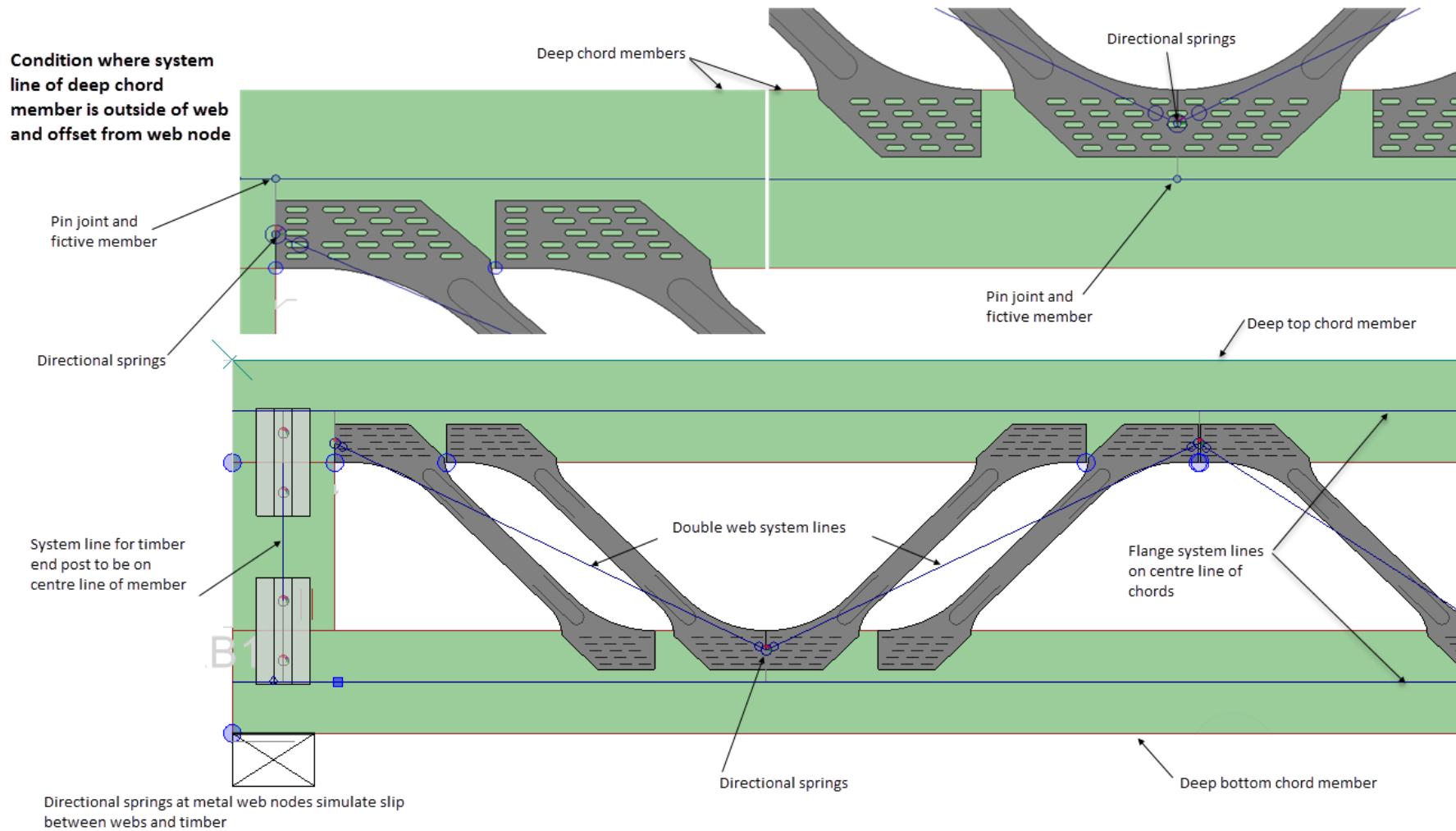


**Figure A 2-3: Structural Model for Metal Web Beams and Columns with Single Webs - (Not to Scale)**

Condition where system line of deep chord member is outside of web and offset from web node



**Figure A 2-4: Structural Model for Metal Web Beams and Columns with Double Webs (Not to Scale)**



### A2.1.2 Flanges

The flanges of the assessed Posi metal web beams and columns were made of TR26 timber (a common strength class in the UK, see Table A 2-1). The nearest equivalent strength class from EN 338 is C27.

**Table A 2-1: Characteristic values for properties of TR26 and C27 flange material**

Mechanical property		Symbol	TR26	C27	Unit
Bending strength	5-%ile	$f_{m,k}$	28.3	27	N/mm <sup>2</sup>
Tension strength parallel to grain	5-%ile	$f_{t,0,k}$	17.6	16.5	N/mm <sup>2</sup>
Compression strength parallel to grain	5-%ile	$f_{c,0,k}$	22.9	22	N/mm <sup>2</sup>
Compression perpendicular to grain	5-%ile	$f_{c,90,k}$	2.6	2.5	N/mm <sup>2</sup>
Shear strength parallel to grain	5-%ile	$f_{v,k}$	4.0	4.0	N/mm <sup>2</sup>
Modulus of elasticity in bending	mean	$E_m$	11000	11500	N/mm <sup>2</sup>
Density	5-%ile	$\rho_k$	370	360	kg/m <sup>3</sup>
Density	mean	$\rho_{mean}$	444	430	kg/m <sup>3</sup>

If using flange material of a different strength class than TR26, then the characteristic strength and stiffness properties are to be taken from EN 338 or the Declaration of Performance for the graded timber.

Design values are to be calculated as

$$f_d = \frac{f_k \times k_{mod}}{\gamma_m}$$

Where  $\gamma_m = 1.3$  and  $k_{mod}$  is taken from Table A 2-2.

**Table A 2-2: Values of  $k_{mod}$**

Load – Duration Class <sup>2</sup>	Service Class 1 and 2 <sup>3</sup>
Permanent action	0.60
Long term action	0.70
Medium term action	0.80
Short term action	0.90
Instantaneous action	1.10

Both flanges are subject to combined axial load (from the triangulated framework) and moment (from local bending between nodes). Flanges subject to combined bending and tension shall be designed in accordance with section 6.2.3 of EN1995-1-1 and the relevant characteristic stresses above. Flanges subject to combined bending and

<sup>2</sup> Load – duration class as defined in EN 1995-1-1, Table 2.1

<sup>3</sup> Service class 1 & 2 as defined in EN 1995-1-1.



compression shall be designed in accordance with section 6.3.2 of EN1995-1-1 and the relevant characteristic stresses above.

The design of the punched metal plate fastener flange splice joints is undertaken using section 8.8.5 of EN 1995-1-1 and characteristic strength properties of a punched metal plate fastener, which have been derived in accordance with EN 14545.

If using flange material of a different strength class than TR26, the characteristic anchorage capacities applicable to Posi metal-web beams and columns shall be obtained by applying the adjustment factor for density to the Posi web characteristic anchorage capacities declared in this ETA.

$$adj. factor = \left( \frac{\rho_{k,ref}}{\rho_{k,TR26}} \right)^{0.5}$$

therefore  $F_{k,ref} = F_{k,PS} \left( \frac{\rho_{k,ref}}{\rho_{k,TR26}} \right)^{0.5}$

Where:

$\rho_{k,ref}$  Characteristic density of reference flange strength class from either EN 338 or the appropriate Declaration of Performance

$\rho_{k,TR26}$  Characteristic density of TR26 timber flange, i.e. 370 kg/m<sup>3</sup>

$F_{k,ref}$  Characteristic anchorage capacity of Posi metal web beam or column with timber flange of reference flange strength class

$F_{k,PS}$  Characteristic Posi-Joist anchorage capacity declared in this ETA

### A2.1.3 Strength of Webs

The minimum steel specification for the metal webs has been submitted to Element Materials Technology Rotterdam B.V. and is held on file.

When designing using the model described in A2.1.1 above, the design web capacities ( $f_{web,d}$ ) are to be taken as:

$$f_{web,d} = \min \begin{cases} f_{web,a,d} \\ f_{web,b,d} \end{cases}$$

$$f_{web,a,d} = \frac{f_{web,a,k} \times k_{mod}}{\gamma_{m,timber}} \quad \text{- the design anchorage capacity}$$

$$f_{web,b,d} = \frac{f_{web,b,k}}{\gamma_{m,steel}} \quad \text{- the design buckling capacity}$$

Where:

$f_{web,a,k}$  is the characteristic anchorage capacity from Table A 2-3 or Table A 2-5

$f_{web,b,k}$  is the characteristic buckling capacity from Table A 2-4 or Table A 2-6

$k_{mod}$  is to be taken from Table A 2-2

$$\gamma_{m,timber} = 1.3$$

$$\gamma_{m,steel} = 1.0$$

**Table A 2-3: Characteristic Posi-Joist™ Web capacities – Anchorage**

Posi ID		Notation	PS8	PS9	PS10	PS10+	PS12	PS14	PS16
Distance Between Flanges (mm)			108	131	159	159	210	279	327
Axial web anchorage capacities (kN)	Single web characteristic anchorage strength in tension at end support	$F_{SW,anch,ES,t,k}$	13.88	13.50	13.59	15.13	13.48	13.09	12.19
	Single web characteristic anchorage strength in tension at internal node	$F_{SW,anch,int,t,k}$	10.67	10.40	9.415	10.77	8.879	8.663	9.246
	Single web characteristic anchorage strength in compression	$F_{SW,anch,c,k}$	14.65	16.07	11.82	13.23	13.08	11.03	11.66
	Double web characteristic anchorage strength in tension	$F_{DW,anch,t,k}$	23.83	22.85	20.12	23.34	20.50	15.35	16.14
	Double web characteristic anchorage strength in compression	$F_{DW,anch,c,k}$	26.70	25.52	24.30	22.62	21.71	17.24	16.53

**Table A 2-4: Characteristic Posi-Joist™ Web capacities – Web Buckling**

Posi-Joist ID		Notation	PS8	PS9	PS10	PS10+	PS12	PS14	PS16
Distance Between Flanges (mm)			108	131	159	159	210	279	327
Axial web buckling capacities (kN)	Single web characteristic compression buckling strength	$F_{SW,buck,k}$	15.57	17.08	12.63	11.45	15.90	11.17	13.19
	Double web characteristic compression buckling strength	$F_{DW,buck,k}$	27.35	26.18	22.18	18.46	24.44	17.69	17.12

**Table A 2-5: Characteristic Posi-Joist™ (Staggered Web) Web capacities – Anchorage**

Posi ID		Notation	PS8	PS9	PS10	PS10+	PS12	PS14	PS16
Distance Between Flanges (mm)			108	131	159	159	210	286	327
Axial web anchorage capacities (kN)	Single web characteristic anchorage strength in tension at end support	$F_{SW,anch,ES,t,k}$	6.940	6.750	6.793	7.56	6.741	6.544	6.096
	Single web characteristic anchorage strength in tension at internal node	$F_{SW,anch,int,t,k}$	5.333	5.202	4.707	5.38	4.440	4.331	4.623
	Single web characteristic anchorage strength in compression	$F_{SW,anch,c,k}$	5.126	5.623	4.137	4.63	4.578	3.861	4.081
	Double web characteristic anchorage strength in tension	$F_{DW,anch,t,k}$	11.91	11.42	10.06	11.67	10.25	7.677	8.067
	Double web characteristic anchorage strength in compression	$F_{DW,anch,c,k}$	9.345	8.933	8.505	7.92	7.597	6.035	5.786

**Table A 2-6: Characteristic Posi-Joist™ (Staggered Web) Web capacities – Web Buckling**

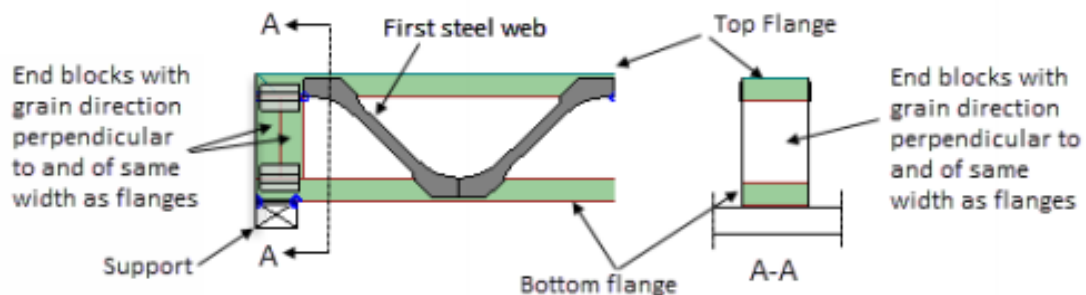
Posi-Joist ID		Notation	PS8	PS9	PS10	PS10+	PS12	PS14	PS16
Distance Between Flanges (mm)			108	131	159	159	210	279	327
Axial web buckling capacities (kN)	Single web characteristic compression buckling strength	$F_{SW,buck,k}$	5.451	5.979	4.421	4.01	5.566	3.910	4.616
	Double web characteristic compression buckling strength	$F_{DW,buck,k}$	9.573	9.164	7.763	6.46	8.552	6.191	5.991

## A2.2 Bearing Strength

Full-flange-width timber end blocks with grain direction perpendicular to flanges are to be placed between the two flanges at support locations as shown in Figure A 2-5. The bearing strength at supports is therefore limited by crushing on the underside of the bottom flange and will be calculated using the procedures of section 6.1.5 of EN1995-1-1 and the relevant characteristic compression stress perpendicular to grain given in Table A 2-1. The bearing strength of metal-web joists, being dependent on the properties of the timber flanges, will be evaluated for differing load-durations using the appropriate  $k_{mod}$  factor given in EN1995-1-1 for structural timber.

For Posi-Studs and X-Rafters, the end blocks are connected to the stud members, but the bearing strength is limited by cross sections of the inner and outer members (stud/rafter flanges) which are fixed direct onto the timber frame sole plate/timber bearer or substrate.

**Figure A 2-5: Typical General Arrangement at Supports**



## A2.3 Stiffness of Beams

When considering serviceability of the Posi metal web beams and columns the design model described in Section A2.1.1 of this Annex is to be used.

The final deflections of the Posi metal web beams should be calculated using expressions (A2.3a) to (A2.3c) below. The expressions are derived from EN1995-1-1, 2.2.3 clauses (3) to (5).

- the final mean moduli of elasticity of the flanges  $E_{mean,fin}$  in (A2.3a) is calculated from the mean moduli of elasticity  $E_{mean}$  of the flanges given in Table A 2-1 above
- the quasi-permanent deflection is determined with the combination of actions given in (A2.3b) and the final mean moduli of elasticity of the flanges  $E_{mean,fin}$  from expression (A2.3a)
- the instantaneous deflection is determined with the combination of actions given in (A2.3c) and the mean moduli of elasticity  $E_{mean}$  of the flanges given in Table A 2-1
- the deflection due to the quasi-permanent combination of actions is superimposed on the instantaneous deflection

$$E_{mean,fin} = \frac{E_{mean}}{(1 + k_{def})} \quad (A2.3a)$$

$$\sum G_{k,j} + \sum \psi_{2,i} Q_{k,i} \quad (A2.3b)$$

$$\sum (1 - \psi_{2,i}) e_{k,i} + \sum (\psi_{0,i} - \psi_{2,i}) e_{k,i} \quad (\text{A2.3c})$$

Where  $k_{\text{def}}$  is taken from Table A 2-7.

**Table A 2-7: Values of  $k_{\text{def}}$**

Service Class 1 <sup>4</sup>	0.60
Service Class 2	0.80

The modulus of elasticity of the webs is to be taken as 205000 N/mm<sup>2</sup>

The slip moduli at the web to flange joints are taken from Table A 2-8 and Table A 2-9.

---

<sup>4</sup> Service class 1 & 2 as defined in EN 1995-1-1.  
ETA 20/1169 of 29/01/2022      EOTA File Number – 22-13-0953

**Table A 2-8: Posi-Joist™ - Characteristic Mean Joint Slip Moduli -  $k_{ser}$**

Posi-Joist ID	Notation	PS8	PS9	PS10	PS10+	PS12	PS14	PS16
Distance Between Flanges (mm)		108	131	159	159	210	279	327
Characteristic mean slip modulus at web nodes (N/mm) Single webs	$k_{ser,SW}$	45000	44700	37000	46000	27900	18900	19900
Characteristic mean slip modulus at web nodes (N/mm) Double webs	$k_{ser,DW}$	43400	52700	25200	32700	18900	16200	21700

Note: The slip moduli presented in this table are specific to flange material with a characteristic density ( $\rho_k$ ) of 370kg/m<sup>3</sup>. When using flange material of a different density, the slip moduli shall be adjusted by using the adjustment factor in section A2.1.2.

**Table A 2-9: Posi-Joist™ (Staggered Web) - Characteristic Mean Joint Slip Moduli -  $k_{ser}$**

Posi-Joist ID	Notation	PS8	PS9	PS10	PS10+	PS12	PS14	PS16
Distance Between Flanges (mm)		108	131	159	159	210	279	327
Characteristic mean slip modulus at web nodes (N/mm) Single webs	$k_{ser,SW}$	22500	22350	18500	23000	13950	9450	9950
Characteristic mean slip modulus at web nodes (N/mm) Double webs	$k_{ser,DW}$	21700	26350	12600	16350	9450	8100	10850

Note: The slip moduli presented in this table are specific to flange material with a characteristic density ( $\rho_k$ ) of 370kg/m<sup>3</sup>. When using flange material of a different density, the slip moduli shall be adjusted by using the adjustment factor in section A2.1.2.

### **Annex 3 Acceptable wood preservative active ingredients**

It is assumed that the following wood preservative active ingredients do not have any effect on the mechanical properties of the timber, provided that they are used within the penetration limits specified in EN 351-1:2007 and they are applied with processes that do not exceed temperatures of 80°C.

For guidance on the choice of the appropriate treatment, reference should be made to either European Product Standards or to the appropriate national, regional or local standards.

Based on the current specifications of the web material, the following types of preservative ingredients can be used.

The acceptable preservative active ingredients are:

1. Water based borate solutions;
2. Water based copper-chromium-based solutions containing either a borate, fluoride, phosphate or an arsenate;
3. Water based borate and guanylurea phosphate solutions;
4. Water based N-Didecyl-N-dipolyethoxyammonium borate, didecylpolyoxethylammonium borate solutions that may contain an organic insecticide;
5. Water based solutions of quaternary ammonium that may contain either IPBC, borates, azoles or some organic insecticides;
6. Azoles solutions based on water with borates or IPBC and organic insecticides.

## **Annex 4 Dimensional Stability and Tolerances**

### **A4.1 Dimensional Stability**

The dimensions of the timber flanges will change due to variations in moisture content between installation and in service conditions throughout its service life. It is recommended that the Posi metal web beams and columns should be made and installed with flanges having a moisture content of maximum 22%.

Throughout the service life this could reduce to 8%, which means that the overall change in moisture content could be up to 14%. For this change in moisture content, it is estimated that the dimensional change in flange depth could be 3.5% (1% change in dimension for every 4% change in moisture content).

It follows that, for a Posi metal web beams and columns with two 47mm deep flanges, the total change in beam depth will be maximum 3.3mm, which is considerably less than the moisture movement in a conventional solid timber joist.

### **A4.2 Dimensional Tolerances**

The webs are manufactured from steel with a thickness of  $1.00 \pm 0.09$  mm, except PS10+ which has a thickness of  $0.90 \pm 0.04$  mm.

The overall length of a metal web beam should not deviate from the nominal length by more than  $\pm 2$ mm

The overall depth of a metal web beam should not deviate from the nominal depth by more than  $\pm 2$ mm

The flange width and depth tolerances are in accordance with Class T2 of EN 336



## **Annex 5 Installation Instructions**

The Manufacturers Installation Guides for Posi-Joist; Trimit; Posi-Stud and X-Rafter shall be followed.

The following points are especially critical.

1. Joists should be installed truly vertical and in the correct orientation.
2. Posi metal web beams and columns must not be notched, drilled or cut, without the express permission of the manufacturer.
3. Posi metal web beams and columns must be fully braced to ensure stability.

For further installation instructions, manufacturer's installation guidelines shall be followed.

## Annex 6 Technical Drawings

The following are technical drawings of end-joined pairs of Posi-Joist webs.

**Figure A 6-1: PS8**

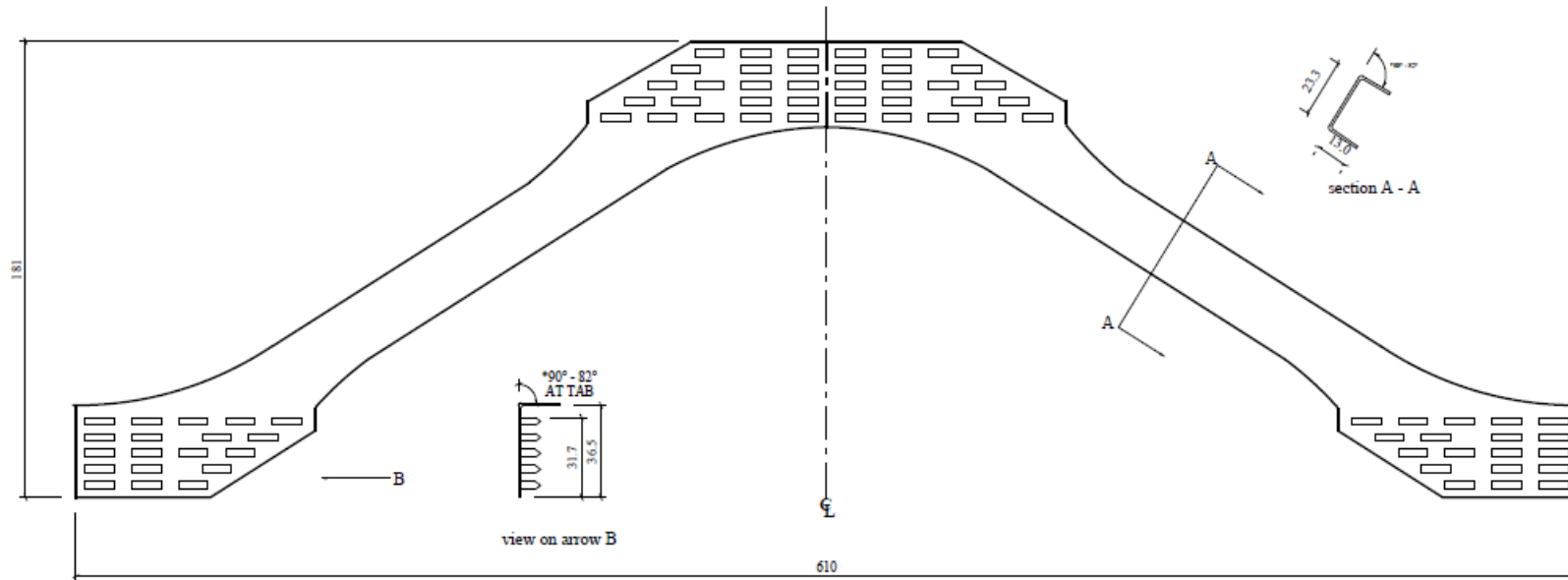


Figure A 6-2: PS9

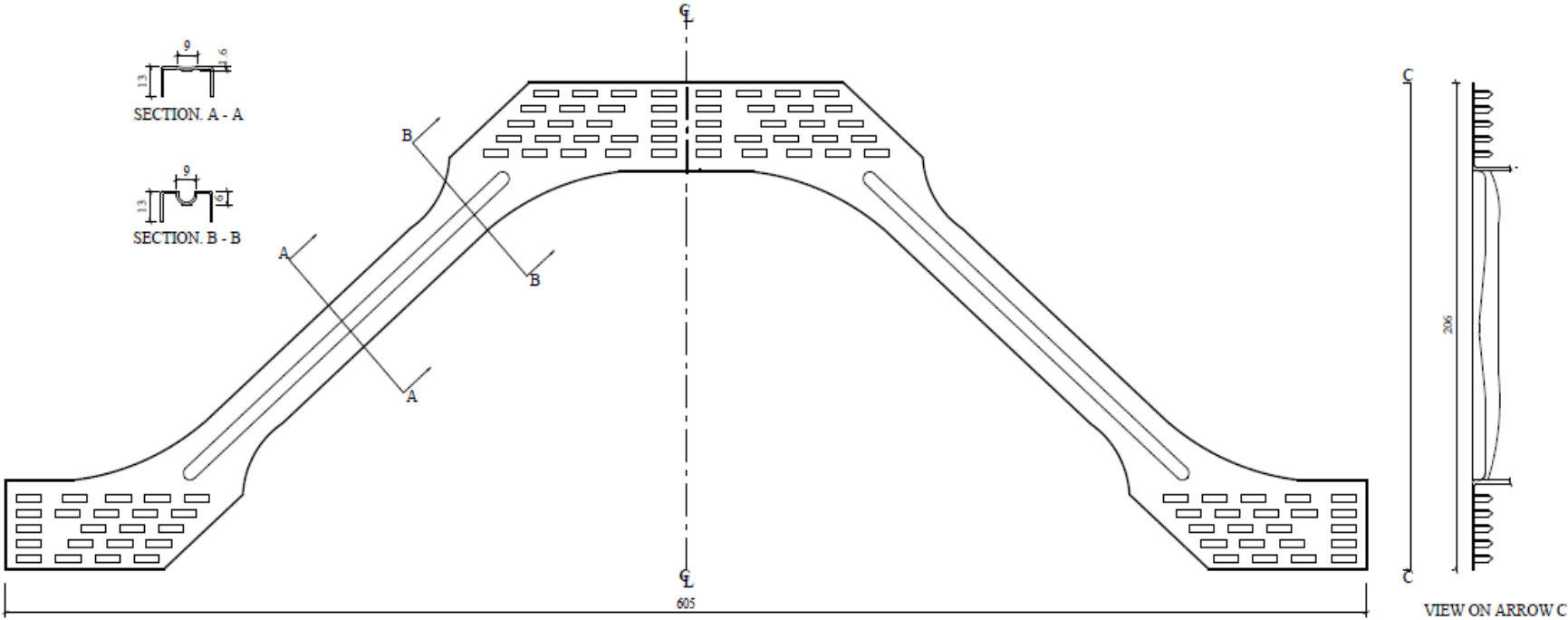


Figure A 6-3: PS10

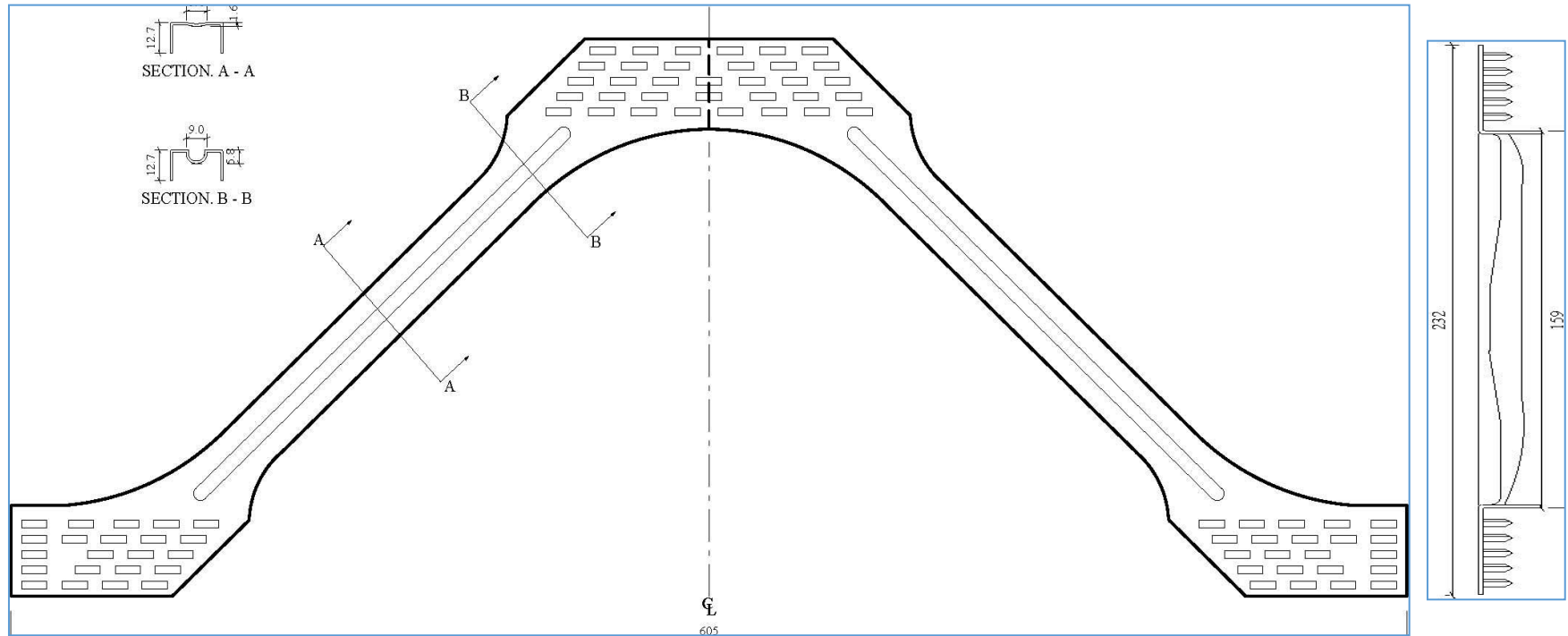


Figure A 6-4: PS10+

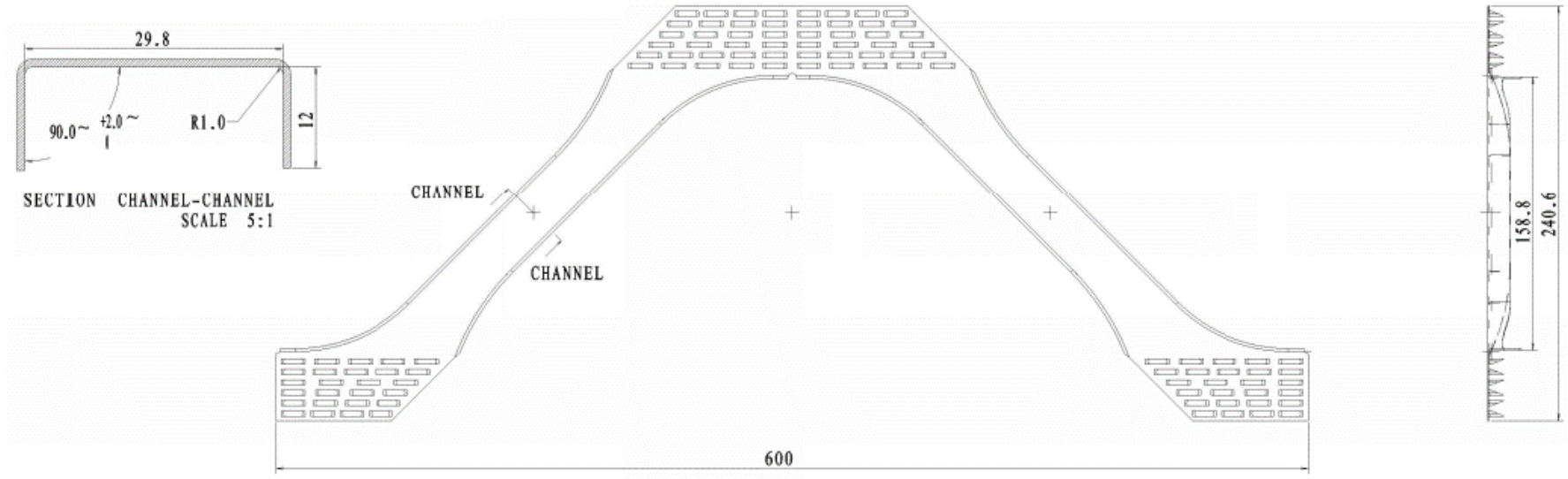


Figure A 6-5: PS12

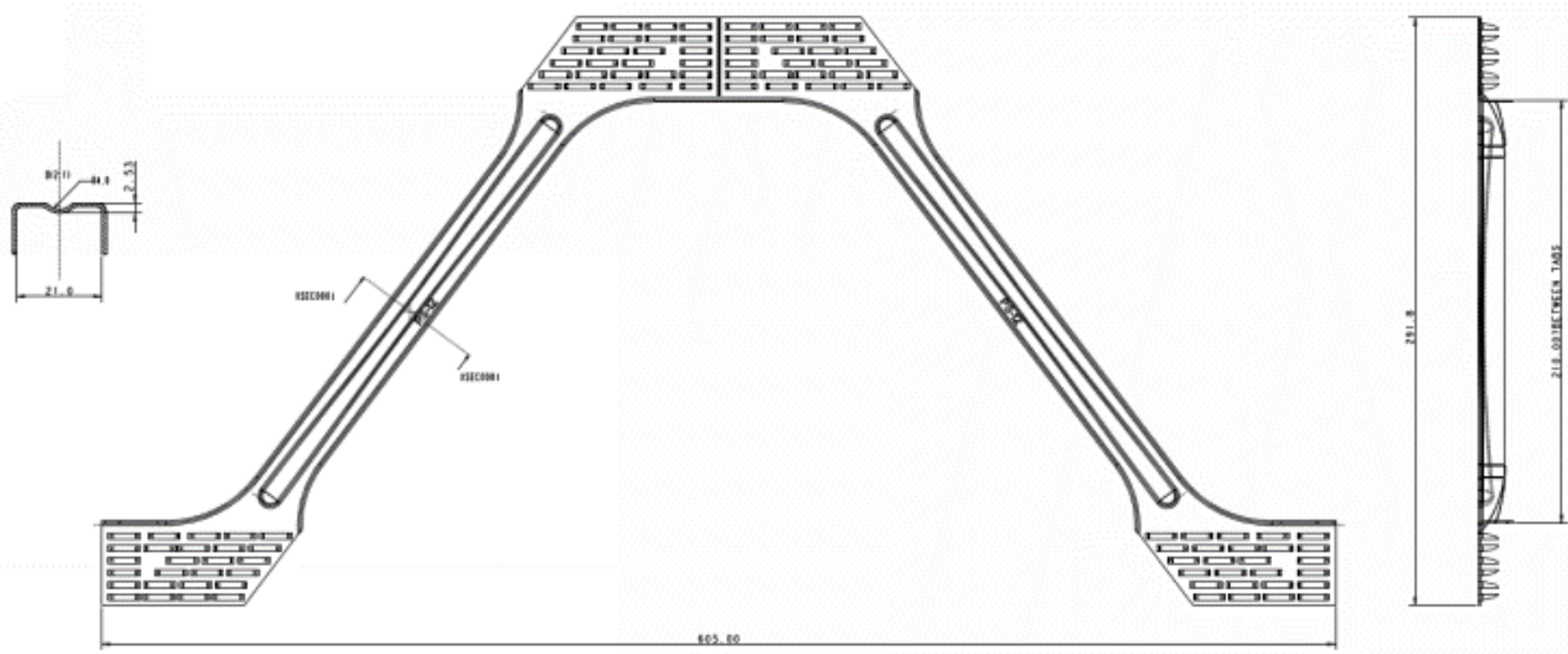


Figure A 6-6: PS14

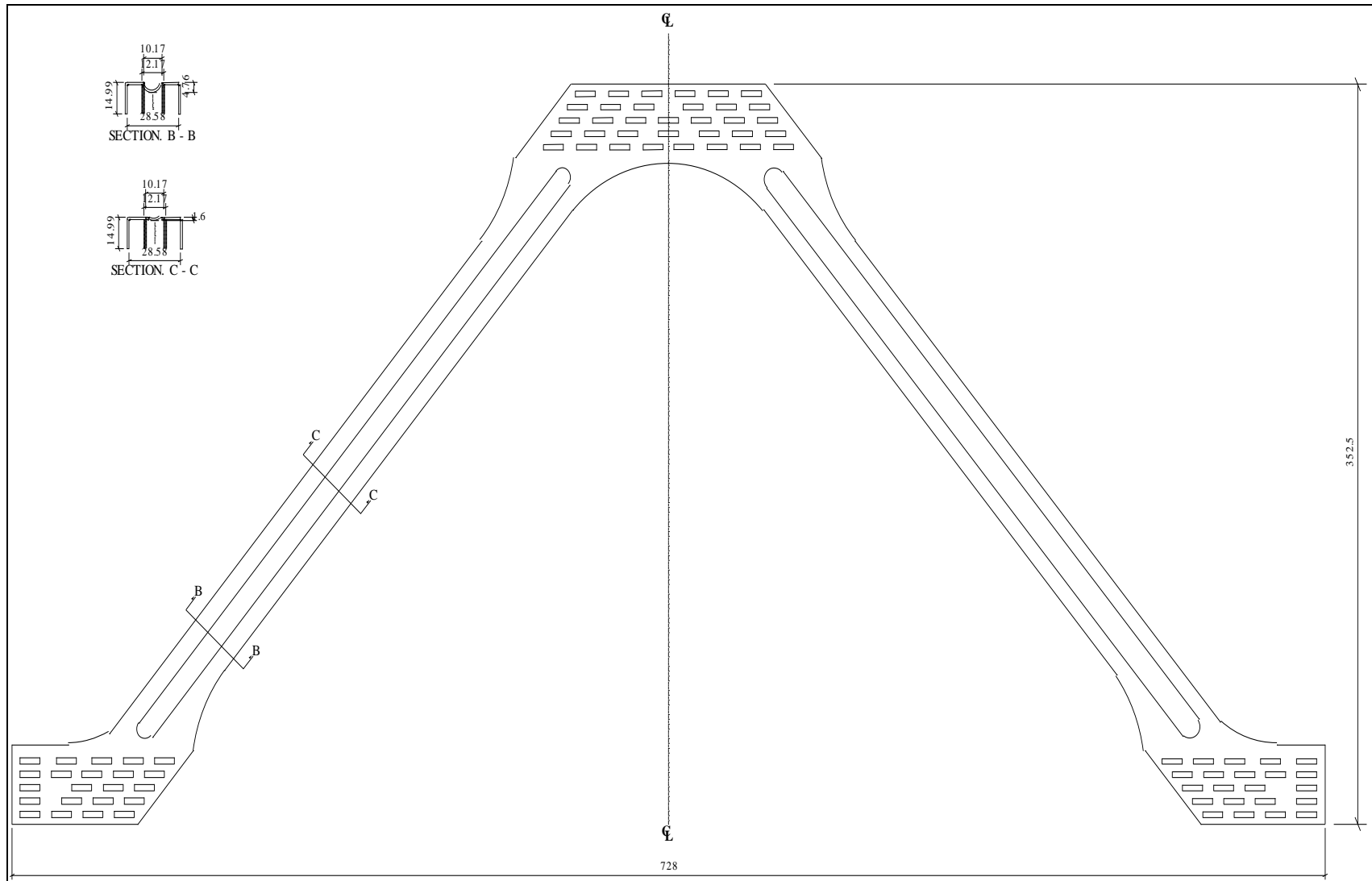


Figure A 6-7: PS16

